

THE DOWNLOAD

© 2009 - BIFMA International

calendar BIFMA EVENTS

The Business and Institutional Furniture Manufacturers Association (BIFMA) International had scheduled the following list of meetings and events as of press time. Additional events will be posted to the BIFMA website on the Internet at www.bifma.org.

January 12, 2010
Statistical Information Committee -
BIFMA Conference Room
Grand Rapids, MI
11:00 am - 4:00 pm

January 27, 2010
BIFMA Board Meeting
9:00 am - via Conference Call

February 8-9, 2010
G1 Work Group (Ergonomics)
Riverview Conference Facility
Grand Rapids, MI
same address as BIFMA Hdqtrs.
9:00 am - 5:00 pm - day one
8:00 am - 4:00 pm - day two

February 24, 2010
Sustainability Committee
Riverview Conference Facility
Grand Rapids, MI
same address as BIFMA Hdqtrs.
1:00 - 4:00 pm Eastern Time

April 13, 2010
Government Affairs Committee
Riverview Conference Facility
Grand Rapids, MI
same address as BIFMA Hdqtrs.
1:00 - 4:00 pm Eastern Time

April 14 & 15, 2010
Educational Seating
Grand Rapids Hilton Inn
Grand Rapids, MI
9:00 am - 5:00 pm - day one
8:00 am - 4:00 pm - day two

level™ Certified Products Now Over 200, Lift-off Successful!

The number of products certified to BIFMA's Furniture Sustainability Standard surpassed 200 in November. Just launched in June of 2009, level™ is the program for third party certification of a product that meets various levels of the sustainability standard. A complete list of all products and further information on level™ can be found at the website:

www.levelcertified.org

The BIFMA Sustainability Standard is a multi-attribute standard modeled after the U.S. Green Building Council's Leadership in Engineering and Environmental Design (LEED) rating system. The standard includes six prerequisites that a product must conform with as well as a number of optional credits. As a product is evaluated against the various credits, it can accumulate points toward achievement at one of three possible conformance levels. The BIFMA standard is holistic in scope in that it addresses the full spectrum of environmental and social attributes.

In order to maintain a distinction between the standard and the method of conformance verification and in an effort to harmonize the branding around certification, BIFMA decided to develop the level™ certification program and BIFMA licenses the use of the level conformance mark to the certification body. NSF, SCS, Intertek, LGA, and UL Environment are

now licensed to certify products to the level™ program. The first public announcement was made at the June 2009 NeoCon furniture show in Chicago. Since then, BIFMA staff and association member company volunteers have been attending many industry shows and other events promoting the program.

BIFMA's Executive Director, Tom Reardon, was invited to Europe in October to present the standard to the FEMB, a group of BIFMA's European counterparts. Several of the participating organizations expressed interest in similar sustainability standard development work within their respective countries. Tom felt there was progress on how the groups could work together and was encouraged by his visit with the FEMB.



Happy Holidays and a Better New Year!

Joy is usually in the air at this time of year and it is our hope that the warmth this holiday season brings you lasts well into and through the coming year. We would also like to express gratitude for your dedication to the association.

BIFMA is only as good and as strong as our members wish it to be. The countless hours that volunteers spend in committee meetings and on special projects are measurable. The ultimate creation of a new standard is also a tangible output. Less quantifiable are things like collaborations that make future projects more feasible, trustworthiness established with stakeholders who witness our process first hand, and international recognition that results in BIFMA being a welcomed voice on global matters. Good things come to hard workers and straight shooters.

Economist Allen Sinai spoke to BIFMA's Leadership Conference last January and correctly predicted that 2009 would be a tough year. He also predicted that the economy would be improving at about this time. (Read Executive Director Tom Reardon's article in this edition of the newsletter for a historical review.) We all hope that 2010 will bring better things to everyone!

Happy Holidays!



Industry Welcomes New Members

BIFMA International welcomes our newest members to the office furniture industry's trade association ranks:

Regular Members:

- Heartwood Manufacturing Ltd. - British Columbia, Canada
- Innovative Seating Solutions - Buffalo, NY
- Jasper Seating Company, Inc. - Jasper, IN
- Trinity Furniture - Trinity, NC
- West Coast Industries, Inc. - San Francisco, CA
- World Furniture Alliance Corp. - St. Louis, MO

Supplier Members:

- Hydro Aluminum - Charlottesville, VA
- ITW Fastex - Des Plaines, IL

International Members:

- United Concepts & Solutions Pvt. Ltd. - Noida, India
- Wipro, Ltd. - Bangalore, Karnataka, India

BIFMA develops voluntary product and industry standards that support safe, healthy and sustainable environments; publishes key industry statistics; advocates for legislation and government regulation that has a direct impact on the health of the industry; and facilitates meaningful dialog and education to support our core services and the industry we serve.

For information on how to join BIFMA and the many benefits of belonging, visit our website at <http://bifma.org/info/index.html>.

Furniture Industry Works Through Challenging Times

The U.S. office furniture industry enjoyed a robust period of growth during the 1990's, starting from \$7.2 billion in shipment volume in 1991 and reaching a peak of \$13.3 billion dollars by the year 2000. We entered the 21st century with three consecutive years of decline (unprecedented since beginning to track shipment volumes in 1972) dropping to \$8.5 billion during 2003, a cumulative 36% decline over that 3-year period. A period of recovery began in 2004 seeing the industry regain some of the lost volume reaching \$11.4 billion in shipments by 2007.

Then came the implosion of the financial markets during 2008. Office furniture shipments held steady through most of the year, but orders started drying up in the 4th quarter ultimately resulting in a drop in shipments of just 2% for calendar year 2008. The industry is expected to decline about 30% in 2009 to a shipment level of about \$7.8 billion. And we see another drop of approximately 5% in 2010 to \$7.4 billion before some recovery in 2011 and beyond.

However, these bleak statistics don't tell the whole story. Based on shipment numbers alone (an industry down 44% from its peak) one might expect dramatic consolidation and wholesale business closures. While there has been some consolidation through acquisitions and a few companies closing down, there have also been several new company start-ups during this time. U.S. Bureau of the Census data indicates a small (3%) decline in the total number of furniture manufacturing companies between 2002 and 2007.

Another factor is that the sales volume data cited above are for office furniture shipments only. Many companies that historically focused on office furniture manufacturing are now diversifying their product lines to include educational, hospitality and healthcare furniture products, and these shipment volumes are not included in the office furniture shipments numbers referenced above. So, in many cases a company's total sales volume has not declined to the same degree as office furniture shipments.

Additionally, as a result of technological advances (i.e. wireless capability, flat screens, etc.) and facility cost containment goals, as well as overall manufacturing efficiencies, workstations are generally becoming smaller and less complex, and therefore less costly. For example, the typical workstation that may have cost \$3,000 years ago might cost \$2,200 today. So even if the industry were selling the same total number of workstations it would likely result in a lower total shipment dollar value.

We provide these statistics and numeric data for perspective, but data and numbers aside, there are many issues that will impact this industry

going forward. As we've pointed out, both industry consolidation and product line diversification are likely to continue. Some of this diversification may be through acquisition (furthering industry consolidation) and some will be through organic growth and line expansion. Successful execution of distribution strategies will be critical to penetrate these other vertical (non-corporate office) market segments, as these segments typically involve a different type of sales process, distribution channel/partner and customer base.

Whether referred to as "green", environmentally preferable, or "sustainable", the identification and procurement of products that have a reduced environmental (and social) impact is a topic that seems to grow daily with no sign of abating. The commercial furniture industry, our customers and relevant stakeholders have taken a proactive position in developing a common, consensus based set of metrics to help define the "sustainable" aspects of furniture. This standard and its supporting conformance verification (certification) program, called level™, provide a framework for the furniture industry to use in developing more sustainable products, processes and companies, as well as a comparative tool for customers seeking to source more sustainable products.

Our collective research, study and understanding of sustainability will grow and evolve over time. Our understanding of how to measure and evaluate the inherent tradeoffs associated with making informed environmental choices will gradually improve. As a society we know more today about making these choices than we did 5 years ago, and in 5 more years we'll know even more. The proactive step that the industry has taken in developing this standard puts us at the forefront of the conversation and learning process and ensures that this industry will continue to lead the way as sustainability measurement tools evolve to the benefit of manufacturers, our customers and society in general.

The furniture industry is presently experiencing some challenging economic times, but individually the vast majority of companies are extremely well managed and well positioned going forward. Collectively, we have a vision of the future and are proactively working toward that positive vision.

Sustainability Standard Educational Events

Allsteel opened the doors of its Chicago Resource Center in October to host representatives from Bernhardt Design, Bush Industries, Gunlocke, Integra, KI, Knoll and National for a BIFMA training session on the Furniture Sustainability Standard and level™ Certification Program. Trainer Paul Shahriari led the half-day program, which prepared the 19 participants to instruct a CEU course on the standard and level™.

level™ is the sustainability standard and third-party certification for the furniture industry that evaluates a company's materials, energy and atmosphere, human and ecosystem health, and social responsibility impacts. BIFMA will be training industry representatives to become "level faculty" and the session at the Allsteel Resource Center was the second to be offered.

are events or audiences that BIFMA should consider in these plans, please contact bmiller@bifma.org with suggestions or invitations.



Tom Reardon of BIFMA at SCS Booth In Phoenix During Greenbuild

The appeal to the American National Standards Institute (ANSI) by the American Forest & Paper Association, Sustainable Forestry Initiative, and Weyerhaeuser will be heard by a non-partial panel on February 23, 2010. We are hopeful that issues raised by the appellants can be satisfactorily addressed this year and that final ANSI approval will be forthcoming.

In the meantime, BIFMA has formed an "Interpretations Consensus Body" that mirrors the standard's Joint Committee membership and will have meetings open to all stakeholders. The purpose of this body is to develop consensus interpretations on any part of the standard to assure consistency in its use and application. Such interpretations will be brought to the Joint Committee for consideration once the standard receives final ANSI approval. To facilitate this process, work groups will be meeting in early January to review the questions that have come in about the standard thus far and to prepare a submittal to the Interpretations Consensus Body. Anyone who wishes to join the work groups listed below should contact BIFMA with their request.

- 1 - Materials Work Group
- 2 - Energy and Atmosphere Work Group
- 3 - Human and Ecosystem Health Work Group
- 4 - Social Responsibility Work Group

There are now 400 stakeholders on the mailing list who receive regular information on developments to the standard. Anyone can get on that mailing list and all are welcome to join work groups, attend meetings, or follow from afar. Email bmiller@bifma.org to be added to the stakeholder list.



Paul Shahriari Training level™ Faculty In Chicago

In addition to training industry personnel, much of 2009 was spent briefing various customer groups. Presentations to the U.S. General Services Administration (GSA), Environmental Protection Agency (EPA), Office of the Federal Environmental Executive, and others have resulted in a higher recognition and appreciation of the standard in Washington. This year, the standard was presented to various audiences at conferences in Baltimore, Toronto, Chicago, and San Antonio. During Greenbuild in Phoenix, short information sessions were delivered on the exposition floor at the invitation of Scientific Certification Systems (SCS), one of the five certification bodies currently certifying level™ products.

2010 promises to be an even bigger year for spreading the word on the BIFMA standard. Talks are underway about sessions at the GSA Expo in May, the EPA's National Environmental Partnership Conference later that same month in Florida, and NeoCon 2010 in Chicago. Additionally, a North American tour is being planned targeted toward the A&D community. If there

Three Standards Prepared For Canvass

New editions of ANSI/BIFMA Standards are being prepared for ANSI Canvass. The BIFMA Engineering Committee and subcommittees have worked to prepare what will be the next editions of the following three ANSI approved BIFMA Standards.

X5.1 General Purpose Office Seating - The scope of this standard has been improved for clarity in the area of upper load limit and expected service life. Other changes include:

1. Section 9, Swivel Test - Cyclic: Changed load from 102 kg (225 lb) to 113 kg (250 lb).
2. Section 11, Seating Durability Tests: Changed bag drop from 1 in. to 1.2 in.
3. Section 12, Stability Tests: Changed this test to use a stack of desks similar to ISO 21015: 2007. The " BIFMA Block", the 173 lb. weight will no longer be used for rear stability testing.
4. Section 13, Arm Strength Test - Vertical - Static: Changed to 169 lbf. Functional Load and 253 lbf. Proof Load.

5. Section 17, Caster/Chair Base

Durability Test - Cyclic: Caster/Chair Base Durability Tests changed from 225 lbf. to 250 lbf.

6. Section 19, Footrest Static Load Test - Vertical: Added this new test.

Note: The changes in Sections 9, 11, 13, and 17 reflect the increases in the weight of the North American population as indicated by the CAESAR Data Study. Section 12 is a new rear stability test that harmonizes with a similar rear stability test in ISO 21015: 2007.

X5.6 Panel Systems - This proposed edition brings the Panel Standard (X5.6) into harmony with the ANSI/BIFMA X5.5-2008 Desk/Table Products and ANSI/BIFMA X5.9-2004 Storage Units Standards. No major changes or additions were made to this proposed new edition.

BIFMA's Furniture Emissions Standards: Test Method M7.1 and

Standard X7.1 - The Test Method M7.1 has undergone major revisions for improved utility and clarity. The majority of the changes and improvements in this document came via suggestions from the emissions testing laboratories who are the main users of the standards and intimately familiar with emissions testing and analytical chemistry. Dr. Jensen Zhang of Syracuse University, Randy Carter of Steelcase, Inc., and an extensive research study provided much of the expertise and scientific basis for revision of the Test Method M7.1 that include:

1. Expanding the use of small scale chamber testing to allow determinations of compliance for assembled furniture products.
2. Defining compliance requirements for individual items (e.g. tables, file cabinets, easels, etc.) in addition to whole workstations and seating.
3. Defining compliance criteria based on emission factors ($\mu\text{g}/\text{m}^2 \text{ h}$) as an option to emission concentrations ($\mu\text{g}/\text{m}^3$) which facilitates suppliers of material assemblies (e.g. laminated work surfaces, surface finishes with

appropriate substrates, etc.) to

provide emissions data relevant to compliance of finished products.

4. Expanding use of the power-law to predict emissions at 14 days from test data at 3 days and 7 days of actual chamber testing.

5. Adding examples to make applying the standards easier and to support the emissions credits in the BIFMA Furniture Sustainability Standard.

6. Multiple technical and analysis refinements to decrease vari-

ation and/or increase harmonization with other standards (ASTM, ISO, etc.).

BIFMA is presently assembling Consensus Bodies (Canvass Lists) of individuals who would be interested in reviewing any or all of the proposed new edition of BIFMA's standards. Canvass participants will provide a vote and comments relevant to the standard(s). Anyone interested in participating in the ANSI Canvass Process should contact BIFMA at: email@bifma.org.

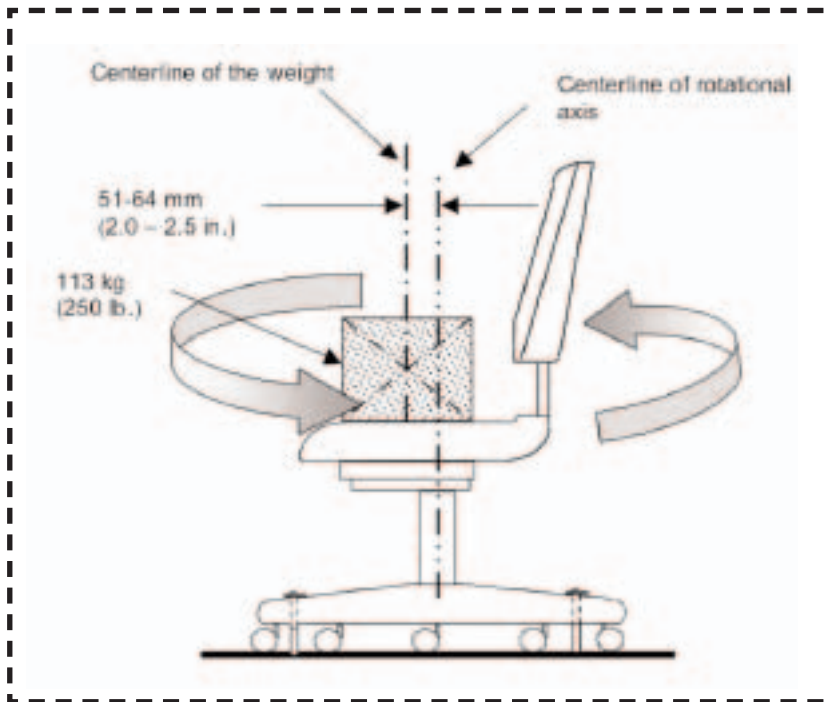

Ergonomics Back On The Front Burner

The BIFMA G1 Work Group (Ergonomics Guideline for VDT Furniture Used in Office Work Spaces) has set a meeting for February 8 & 9, 2010 to be held at Riverview Conference Center (same building as BIFMA's Headquarters). The entire Ergonomics and Chair Subcommittees have been notified of this meeting so that anyone interested in becoming part of this work group can do so. The meeting will focus on anthropometric data review and "word-smithing" of a proposed new G1 document that will subsequently be reviewed by the Ergonomics and Chair Standard Subcommittees.

This is an area that will see more activity in coming years. The U.S. Green Building Council's LEED Rating System has referenced BIFMA's guideline and the Obama Administration is seeking to curb workplace injuries

from repetitive-stress injuries. In December, the U.S. Labor Department proposed requiring companies in the U.S. to keep more extensive records of ergonomic-related injuries.

Meanwhile, the 2010 Applied Ergonomics Conference (AEC) is shaping up to be one of the largest and most impressive ergonomics conferences in North America for the coming year. The planned presenters are well-respected ergonomics practitioners sharing real-world experiences and practical solutions to common problems in industry. This conference provides comprehensive and broad-spectrum education for ergonomics professionals at all levels. The conference will be held March 22- 25 at the J.W. Marriott San Antonio Hill Country Resort and Spa.

Formaldehyde Bill Clears Committee

The Formaldehyde Standards for Composite Wood Act, S. 1660, passed the U.S. Senate Committee on Environment and Public Works in December. The legislation, introduced in September by Senators Amy Klobuchar (D-MN) and Mike Crapo (R-ID), directs the Environmental Protection Agency to establish a national emission standard under the Toxic Substances Control Act. Under the proposed legislation, particleboard, MDF and hardwood plywood made or sold in the U.S. – and products made from them – would have to meet the formaldehyde emission ceilings in California's recently adopted emissions standard.

The amended legislation calls for EPA to act by Jan. 1, 2012, with the regulation to go into effect 180 days after promulgation. In addition to

establishing the national standard, this legislation would:

- Direct EPA to establish third-party testing and certification requirements to ensure that products comply with the national standard
- Direct EPA to work with Customs and Border Protection and other relevant federal agencies to enforce the standards for both domestic and imported wood products
- Direct EPA to establish other necessary implementation and enforcement regulations

BIFMA is working with a coalition of groups supporting this legislation and plans to work with EPA after passage of the legislation on the details of implementation and enforcement issues.

USDA Action Threatens Wood Supply

A regulation by the U.S. Department of Agriculture (USDA) threatens the existence of many US-based wood product manufacturers. The USDA's Biomass Crop Assistance Program (BCAP), while well intended, could have unintended consequences by transferring wood material (like wood chips and sawdust) from industries making consumer and construction products to the biomass fuel industry for alternative energy purposes.

A \$500 million subsidy will fuel this problem beginning in 2010 unless steps are taken to reevaluate the policy and change the list of raw materials eligible for a federal subsidy. As proposed by USDA's Farm Service Agency, BCAP has a laudable goal of fostering the diversification of America's fuel supply by subsidizing "renewable biomass" alternatives to traditional fossil fuels. Unfortunately, BCAP's list of eligible materials includes residual wood that is already being used for higher value purposes in homes, furniture, cabinets, doors, flooring and other consumer and construction products.

The 2008 Farm Bill states that renewable biomass includes materials that "would not otherwise be used for higher-value products." BCAP's inclusion of wood used for higher value products is contrary to this directive. BCAP's purpose was to incentivize the collection of unused and under-utilized wood and agriculture scraps resulting from farming and timber activities.

According to the Composite Panel Association (CPA), the magnitude of the proposed 2010 BCAP subsidy is enough to wipe out the entire feedstock of U.S. composite panel manufacturers (estimated at \$400 million in 2010). BIFMA has joined a growing coalition of groups urging Congress to restructure BCAP to meet the program's original intent by removing higher value industrial raw materials from those eligible for a federal subsidy. This simple change would still incentivize U.S. landowners to expand the bio-based domestic fuel supply while doing no harm to the traditional industries that currently sequester carbon rather than releasing it through combustion.

“Conversations In Design” Debuts At IDS 10

The Interior Design Show's *IDS 10: The Ultimate Design Experience* will be held January 21 to 24, 2010 at the Metro Toronto Convention Centre. New this year is the inaugural “Conversations in Design” to be launched on January 21. Leading designers from around the globe are invited to imagine A World Without Oil at an all-day symposium in Toronto. They will share their practical experiences in sustainable design, and dare to dream of a society that is no longer dependent on oil.

The symposium will provide critical insight to new and alternative practices, materials, technologies and products. It will challenge its audience to think outside the box, and ultimately illuminate and inspire on the provocative subject of A World Without Oil.

The innovative designer and futurist Bruce Mau will discuss his picture perfect world where a future civilization thrives on alternative energy

sources and no longer relies on oil.

Co-founder of the Biomimicry Guild, Dr. Dayna Baumeister will share with guests how Biomimics around the world are learning to grow food like a prairie, harness energy like a leaf, create color like a peacock, find cures like a chimp, compute like a cell, and run a business like a redwood forest.

Industrial designer Tord Boontje will describe his vision to “design with conscious” as he strives to integrate social and environmental responsibility into his work.

The symposium is recognized by the Interior Design Continuing Education Council (IDCEC) and attendees can claim 0.6 CEUs for full day and 0.3 CEUs for half day.

Event website: <http://www.interiordesignshow.com>

LCAs, EPDs & Product Category Rules

Life Cycle Assessment (LCA) is a technique for analyzing the entire life cycle of a product or process. The term “life cycle” refers to the major activities in the course of the product’s life-span from its manufacture, use, and maintenance, to its final disposal, including the raw material acquisition required to manufacture the product.

Environmental product declarations (EPDs) are disclosure of the environmental performance of products in such a way that the consumer can make side-by-side comparisons of different products, much like a nutrition label does. Product category rules (PCRs) are a set of specific rules, requirements, and guidelines for developing EPDs for one or more product category.

Call for Product Category Rules Task Group Volunteers

The U.S. Environmental Protection Agency (EPA) recently held a workshop focusing on Environmental Product Declarations (EPDs) with

governmental representatives (EPA & GSA), LCA tool developers, product manufacturers, and others present where they encouraged industries to collaborate on the development of Product Category Rules. At their November meeting, the BIFMA Sustainability Committee discussed EPA’s request and has created a Product Category Rules Task Group to coordinate the input of the office furniture industry. It will be chaired by Gabe Wing of Herman Miller and is open to any interested BIFMA member that wishes to participate. Please email bmiller@bifma.org to join this task group.

The American Center for Life Cycle Assessment has announced their annual conference dates. LCA X will be held in Portland, Oregon the first week of November, 2010. The theme will be “Bridging Science, Policy and the Public” and a presentation on the BIFMA Furniture Sustainability Standard’s use of life cycle thinking is under consideration.

Meet Us In Person, Or Meet Us Online

In this era of tight budgets and what seems like regular obstacles to travel as we have known it (airline scheduling woes, influenza concerns, changing security measures, etc.), it is good to know that technology can help keep us communicating between the events we do see each other at. BIFMA continues to explore ways to enhance WebEx and other remote meeting tools. Additionally, a BIFMA LinkedIn Group has been in test mode for several weeks. We hope to send invitations to all our members to join this open forum in early 2010.

Besides virtual meeting and social media additions, BIFMA will unveil a new website in 2010 with several new functions that will make information delivery quicker and easier for users.

While the BIFMA Leadership Conference has been postponed due to the economic climate, the planning committee will be gathering in early January to make plans for 2011. Technology is great, but nothing takes the place of the old fashioned person-to-person camaraderie and chance to focus on a topic without disruption. We’ll be “seeing you” soon!

The Download is published quarterly by BIFMA International to provide a brief update of association activities.

BIFMA International
678 Front Ave., NW, Suite 150
Grand Rapids, MI 49504-5368
Phone 616-285-3963 / Fax 616-285-3765
email@bifma.org / Website www.bifma.org

BIFMA Staff

Thomas Reardon *Executive Director*

Richard Driscoll *Director-Technical Services*

Brad Miller *Director-Government Affairs*

Michael Reagan *Manager-Administration
and Statistical Information*

Roxanne DeBoer *Administrative Assistant*

Editorial Staff

Brad Miller

Roxanne DeBoer

BIFMA Officers and Directors

President

Rebecca Boenigk, Neutral Posture, Inc.

Vice President

Stan Askren, HNI Corporation

Treasurer

Daniel Tuohy, Tuohy Furniture Corporation

Directors

Anne Bernhardt, Bernhardt Design

Franco Bianchi, Haworth Inc.

Mikel Briggs, Bretford Manufacturing, Inc.

Bill Bundy, Trendway Corporation

Joel Feldberg, The Global Group

Jim Keane, Steelcase Inc.

Shaun Mannix, Transwall

Hank Menke, OFS Brands

P. Daniel Miller, Kimball International Inc.

Chuck Saylor, izzy+

Lynn Utter, Knoll, Inc.

Brian Walker, Herman Miller Inc.

THE DOWNLOAD

© 2009 - BIFMA INTERNATIONAL

CALENDAR of industry events

Updated regularly on BIFMA's Internet Site: www.bifma.org

January 19-24, 2010 - The International Furniture Fair (IMM) - Cologne, Germany; <http://www.furniturefair-cologne.com>

January 21-24, 2010 - Interior Design Show's "IDS 10: The Ultimate Design Experience" - Metro Toronto Convention Centre; website: <http://www.interiordesignshow.com>

January 22-25, 2010 - Furnidec Business 2010; 4th Professional International Exhibition of Furniture, Greece, <http://www.helexpo.gr>, +30 2310 291111

January 25-27, 2010 - 10th London ASIA Expo; National Hall, Olympia, London <http://www.londonasiaexpo.com>

February 8-11, 2010 - ZOW Furniture Supply Show, Bad Salzflun, Germany; www.zow-messe.com

March 2-6, 2010 - Malaysian International Furniture Fair - Kuala Lumpur; www.miff.com.my

March 9-12, 2010 - IFFS/AFS 27th ASEAN Furniture Show, Singapore Expo; Tel: (65) 6569 6988 Fax: (65) 6569 9939; Email: enquiry@iffs.com.sg; <http://www.iffs.com.sg>

March 12-15, 2010 - (TILS) Taipei International Lighting & Furniture Show; Taipei World Trade Center Exhibition Hall; Toronto@taitra.org.tw or 416-363-9946 ext. 102 Fax: 416-363-2023

March 9-12, 2010 - IFFS/AFS Singapore Expo - International Furniture Centre, Singapore; Tel: (65) 6569 6988; Fax: (65) 6569 9939; Email: enquiry@iffs.com.sg; <http://www.iffs.com.sg>

March 24-26, 2010 - GLOBE 2010 - Vancouver, Canada; 604-633-0703; trish@globe.ca; www.globe2010.com

April 27-29, 2010 - Consumer Products Conference; Miami Beach, FL; <http://www.inda.org>

May 4-6, 2010 - GSA's National Product Expo - Orlando, FL; <http://www.expo.gsa.gov>

May 4-8, 2010 - XYLEXPO 22nd Biennial World Exhibition for Woodworking Technology and Furniture Suppliers in Assago MI, Italy; +39-02-89210200 Internet: <http://www.xylexpo.com/eng>

May 19-21, 2010 - 7th Annual Greening the Heartland Conference - Minneapolis, MN ; <http://www.greeningtheheartland.org>; General Info: 866-933-4GRN or 314-621-2033

May 23-25, 2010 - Hardwood Plywood & Veneer Association's Spring Convention, at DoubleTree Paradise Valley Resort, Scottsdale, AZ; <http://www.hpva.org>

May 25-27, 2010 - EPA's National Environmental Partnership Summit - Orlando, FL; <http://www.environmentalsummit.org>

June 14-16, 2010 - Annual NeoCon® World's Trade Fair - Chicago, IL; Contact: Merchandise Mart Properties, Inc.; Telephone: 800-643-6074 or 312-527-7300; <http://www.mmart.com/mmart>

June 16, 2010, BIFMA International's Annual Meeting - Chicago, IL; Telephone: 616-285-3963; Fax: 616-285-3765; Email: email@bifma.org; <http://www.bifma.org/events/index.html>

June 16, 2010, BIFMA International's Annual Meeting - Chicago, IL; Telephone: 616-285-3963; Fax: 616-285-3765; Email: email@bifma.org; <http://www.bifma.org/events/index.html>

October 9-12, 2010 - OFDA Dealer Strategies Conference & Expo - Hyatt Regency Coconut Point Resort and Spa, Bonita Springs, FL; Internet: <http://www.ofdanet.org>